

Effective date: 10 June 2019

Status: Approved



Class Rules

International Formula 18 Class Association



The International Formula 18 catamaran formula was developed in 1993 by Olivier Bovyn and Pierre-Charles Barraud and was adopted as a Recognised Class in 1996 and as an International Class in 2002.

sport / nature / technology



World Sailing
Class Association

INDEX

PART I – ADMINISTRATION

Section A – General

A.1	Language	4
A.2	Abbreviations	4
A.3	Authorities	4
A.4	Administration of the Association.....	4
A.5	WS Rules	4
A.6	Class Rules Changes	4
A.7	Class Rules Amendments	4
A.8	Class Rules Interpretation	5
A.9	International Class Fee and WS Building Plaque.....	5
A.10	Record of Measurement Certificates	5
A.11	Boat Certification.....	5
A.12	Initial Boat Certification	5
A.13	Validity of Certificate	5
A.14	Boat Re-certification	6
A.15	Retention of Certification Documentation	6

Section B – Boat Eligibility

B.1	Class Rules and Certification.....	6
B.2	Certification Marks	6

PART II – REQUIREMENTS AND LIMITATIONS

Section C – Conditions for Racing

C.1	General.....	7
C.2	Advertising.....	7
C.3	Crew.....	7
C.4	Personal Equipment.....	8
C.5	Portable Equipment.....	8
C.6	Boat.....	9
C.7	Hulls.....	9
C.8	Hull Appendages.....	10
C.9	Rig.....	10
C.10	Sails	11

Section D – Hull

D.1	Parts	11
D.2	General.....	12
D.3	Hull shells	12
D.4	Beams	12
D.5	Trampoline.....	13
D.6	Platform	13

Section E – Hull Appendages

E.1	Parts	14
E.2	General.....	14
E.3	Centreboard/Daggerboard.....	15
E.4	Rudder Blade, Rudder Stock and Tiller.....	15

Section F – Rig

F.1	Parts	16
F.2	General.....	16
F.3	Mast	17
F.4	Boom	18
F.5	Bowsprit.....	18
F.6	Standing Rigging	18
F.7	Running Rigging.....	19

Section G – Sails

G.1	Parts	19
G.2	General.....	20
G.3	Mainsail	20
G.4	Jib.....	21
G.5	Gennaker	22

PART III – APPENDICES

Appendix A – Builder's declaration.....	23
Appendix B – Sailmaker's declaration..	24
Appendix C – Class Drawings.....	25
Appendix D – Cloth List.....	39

INTRODUCTION

This introduction only provides an informal background and the International Formula 18 Class Rules proper begin on the next page.

The overall objective of the Formula 18 class is to offer popular, exciting, safe and fair racing in 18-foot catamarans.

The class' further objective is to keep development under control, maintaining a good balance between cost and performance. Being open to any manufacturer promotes competition and keeps costs to sailors to a minimum.

The platform weight allows robust construction, increasing longevity. It also facilitates adding interchangeable parts to the platform, for example for use as a foiling catamaran outside F18 racing.

The use of crew extra weights allows for fairer racing with more women and youth involved as helms and crews.

Formula 18 platforms, hulls, hull appendages, rigs and sails are measurement controlled.

Rules regulating the use of equipment during a race are contained in Section C of these class rules, in ERS Part I and in the Racing Rules of Sailing.

PLEASE REMEMBER:

THESE RULES ARE **CLOSED CLASS RULES** WHERE IF IT DOES NOT SPECIFICALLY SAY THAT YOU MAY – THEN YOU SHALL NOT.

COMPONENTS, AND THEIR USE, ARE DEFINED BY THEIR DESCRIPTION.

PART I – ADMINISTRATION

Section A – General

A.1 LANGUAGE

- A.1.1 The official language of the IF18CA is English and in case of dispute over translation the English text shall prevail.
- A.1.2 The word “shall” is mandatory and the word “may” is permissive.

A.2 ABBREVIATIONS

- A.2.1 WS World Sailing
- MNA WS Member National Authority
- IF18CA International Formula 18 Class Association
- NCA National Formula 18 Class Association
- ERS Equipment Rules of Sailing
- RRS Racing Rules of Sailing

A.3 AUTHORITIES

- A.3.1 The international authority of the IF18CA is WS which shall co-operate with the IF18CA in all matters concerning these **class rules**.
- A.3.2 Notwithstanding anything contained herein, the IF18CA has the authority to withdraw a **certificate** and shall also do so on the request of WS.
- A.3.3 The IF18CA shall keep a record of the **official measurers**.

A.4 ADMINISTRATION OF THE ASSOCIATION

- A.4.1 The class is administered by the IF18CA.
- A.4.2 At national level, a NCA administers the class, by IF18CA delegation. In countries where there is no NCA, then IF18CA will cover such duties.

A.5 WS RULES

- A.5.1 These **class rules** shall be read in conjunction with the ERS.
- A.5.2 Except where used in headings, when a term is printed in “**bold**” the definition in the ERS applies and when a term is printed in “*italics*” the definition in the RRS applies.

A.6 CLASS RULES CHANGES

- A.6.1 At events organised under these **class rules** RRS 87 and WS Regulation 10.5(f) apply.

A.7 CLASS RULES AMENDMENTS

- A.7.1 Amendments to these **class rules** are subject to the approval of WS in accordance with WS Regulations and the IF18CA in accordance with its constitution.

A.8 CLASS RULES INTERPRETATION

- A.8.1 Interpretation of these **class rules** shall be made in accordance with WS Regulations.
- A.8.2 These **class rules** shall take precedence over the measurement **certificate**.
- A.8.3 Any interpretation of these **class rules** required at an event may be made by the international jury constituted in accordance with RRS (appendix N). Such interpretation shall only be valid during the event and the organising authority shall, as soon as practical after the event, inform WS, the MNA and the IF18CA.

A.9 INTERNATIONAL CLASS FEE AND WS BUILDING PLAQUE

- A.9.1 International class fee shall be paid every year to WS.
- A.9.2 From 1 November 2009 all new boats shall have WS plaques affixed to the **boats** (see D.2.3).

A.10 RECORD OF MEASUREMENT CERTIFICATES

- A.10.1 Each NCA shall keep a complete record of all F18 catamarans and **sails** that have been **certified** within that country.

A.11 BOAT CERTIFICATION

- A.11.1 A **certificate** shall record the following information:
 - (a) Class
 - (b) **Certification authority**
 - (c) Measurement certificate number issued by the **certification authority**
 - (d) Owner
 - (e) **Hull** identification
 - (f) Builder/manufacturers details and agreement that **boat** and **sails** are made in line with IF18CA **class rules** ; builder's/sailmaker's declaration.
 - (g) Date of issue of initial **certificate**
 - (h) Date of issue of **certificate**.

A.12 INITIAL BOAT CERTIFICATION

- A.12.1 For a **certificate** to be issued to a boat not previously **certified**:
 - (a) **Certification control** shall be carried out by the **official measurer** who shall complete the appropriate documentation.
 - (b) The documentation and **certification** fee, if required, shall be sent to the **certification authority**.
 - (c) Upon receipt of a satisfactorily completed documentation and **certification** fee, if required, the **certification authority** may issue a **certificate**.

A.13 VALIDITY OF CERTIFICATE

- A.13.1 A **certificate** becomes invalid upon:
 - (a) the change to any items recorded on the **boat certificate** as required under A.11.1

- (b) any alteration to **corrector weights**
- (c) withdrawal by **certification authorities**
- (d) the issue of a new **certificate**.

A.14 BOAT RE -CERTIFICATION

- A.14.1 The **certification authority** may issue a **certificate** to a previously **certified boat**:
- (a) when it is invalidated under A.13.1(a) or (b), after receipt of the old **certificate**, and **certification** fee if required.
 - (b) when it is invalidated under A.13.1(c), at its discretion.
 - (c) in other cases, by application of the procedure in A.12.

A.15 RETENTION OF CERTIFICATION DOCUMENTATION

- A.15.1 The **certification authority** shall:
- (a) retain the original documentation upon which the current **certificate** is based.
 - (b) upon request, transfer this documentation to the new **certification authority** if the **boat** is exported.

Section B – Boat Eligibility

For a **boat** to be eligible for *racing*, it shall comply with the rules in this section.

B.1 CLASS RULES AND CERTIFICATION

- B.1.1 The **boat** shall:
- (a) be in compliance with these **class rules**.
 - (b) have a valid **certificate** for platform, **hull appendages, rig and sails**.
 - (c) have valid **certification marks** as required.
 - (d) have a completed, signed and dated measurement **certificate**.
- B.1.2 A **certificate** may be refused if there is any doubt over compliance with these **class rules**. An **official measurer** shall report on the measurement **certificate** anything which he considers in breach of these **class rules**, and shall not sign the **certificate**. A copy of the incomplete **certificate**, together with an explanation of the points in question, shall immediately be sent to the IF18CA secretariat and WS for a ruling in writing.
- B.1.3 All **certified boats** may be liable to re-measurement at the discretion of the **certification authority** or by an international jury constituted in accordance with the RRS (Appendix N) at an event, but only by an **official measurer**.

B.2 CERTIFICATION MARKS

- B.2.1 A valid association sticker as required by the IF18CA shall be affixed to each measured item in the required position (see the diagram B.2 certification marks in Appendix C), as a part of **certification marks**.

PART II – REQUIREMENTS AND LIMITATIONS

The intention of these **class rules** is to ensure that the boats are as alike as possible in all aspects affecting performance as F18 is a measurement-controlled class. The **crew** and the **boat** shall comply with the **class rules** in part II when *racing*. In case of conflict, section C shall prevail.

The **class rules** in part II are **closed class rules** where anything not specifically permitted by the **class rules** is prohibited. **Certification control** and **equipment inspection** shall be carried out in accordance with the ERS except where varied in this part.

Section C – Conditions for Racing

C.1 GENERAL

C.1.1 RULES

- (a) The ERS shall apply.
- (b) RRS 49.1 shall not apply (regards: **crew** position; lifelines).
- (c) RRS Appendix G.1.3 (d) shall not apply (regards: national letters and **sail** number on a gennaker).

C.2 ADVERTISING

C.2.1 LIMITATIONS

- (a) Advertising shall only be displayed in accordance with the WS Advertising code.

C.3 CREW

C.3.1 MEMBERSHIP

- (a) **Crews** are not permitted to enter a Formula 18 event unless they are current members of their NCA.
- (b) In countries where there is no NCA, **crews** shall be member of the IF18CA.

C.3.2 LIMITATIONS

- (a) The **crew** shall consist of 2 persons.
- (b) The **crew** shall be dressed in underwear or swimming costume without shoes when weighed.
- (c) The **crew** shall use the **sails** (as defined in G.4.3 and G.5.3) in accordance with the following weight categories:
 - (1) **Crew** from 115 kg to less than 130 kg shall sail with the Small Jib and Small Gennaker and then shall carry extra weight equal to half the difference between their actual weight and 130 kg.
 - (2) **Crew** weighing 130 kg and over may sail with the Small Jib and the Small Gennaker and shall not carry extra weight.

- (3) **Crew** between 130 kg and 135 kg may use the Large Jib and Large Gennaker and then shall carry extra weight equal to the difference between their actual weight and 135 kg plus 7.5 kg.
- (4) **Crew** between 135 kg and 150 kg may use the Large Jib and Large Gennaker and shall carry extra weight equal to half the difference between their actual weight and 150 kg.
- (5) **Crew** weighing 150 kg and over may use the Large Jib and the Large Gennaker without carrying any extra weight.

C.3.3 WEIGHTS

- (a) The minimum combined **crew** weight is 115 kg
- (b) They are FOUR categories of **crew** weight:
 - (1) from 115 kg to less than 130 kg
 - (2) from 130 kg to 135 kg
 - (3) from 135 kg to 150 kg
 - (4) 150 kg and over.
- (c) **Crew** extra weights shall be of metal and securely fastened on the port side, either to the outside of the front beam or to the strut, and shall be removable for checking.
- (d) **Crews** may be weighed at registration for a regatta and may be reweighed at any time by the race committee.

C.4 PERSONAL EQUIPMENT

C.4.1 MANDATORY

- (a) The **crew** shall wear a **personal flotation device** to the minimum standard EN393, ISO 12402-5 (CE 50 Newtons), USCG Type III, or AUS PFD 2.

C.4.2 OPTIONAL

- (a) **Trapeze** harness for each member of **crew**
- (b) All other **personal equipment**.

C.5 PORTABLE EQUIPMENT

C.5.1 MANDATORY

- (a) Righting line, minimum 3.5 metres long and minimum 8 mm diameter
- (b) Towing line, minimum 15 metres long and minimum 6 mm diameter
- (c) Items required in accordance with the notice of race.

C.5.2 OPTIONAL

- (a) Steering compass(es)
- (b) Timing device(s)
- (c) Knife(s)
- (d) Mechanical wind indicator(s)
- (e) Items permitted in accordance with the notice of race.

C.6 BOAT

C.6.1 WEIGHT

(a) PLATFORM

- (1) The minimum weight of the platform shall be 130 kg.
- (2) The platform shall be weighed assembled. It comprises: the assembled **hulls**, the trampoline, the **hull appendages**, tiller, tiller extension, main **sheet** and jib **sheet** systems, compass(es), **corrector weights**, righting line and all equipment and control lines normally bolted, screwed or fixed in a permanent manner on the **boat**, not to include the towing line.

(b) BOAT READY TO SAIL

- (1) The total weight of the **boat**, ready to sail, shall not be less than 180 kg.
- (2) The weight of the **boat** ready to sail shall be the platform as in C.6.1(a) carrying the equipment normally used for navigation with the **rig** as in C.9 and a set of **sails** with battens as in C.10.
- (3) The weights of the platform (C.6.1(a)) and of the **boat** ready to sail (C.6.1(b)), each excluding **corrector weights**, and the **certificate** number shall be indelibly written by the measurer in line with appendix C diagram “(b) BOAT READY TO SAIL (3) Identification”.

C.6.2 CORRECTOR WEIGHTS

- (a) A maximum of 7 kg of **corrector weight** is allowed to comply with both platform and **boat** ready to sail minimum weights.
- (b) **Corrector weights shall** be securely fastened to the outside on the starboard side of the front beam or to the strut and shall be removable for checking.
- (c) **Corrector weights shall** be of metal.

C.6.3 FLOATATION

- (a) It is the responsibility of the *person in charge* to ensure at all times the water tightness of the **boat**.
- (b) If there is any doubt regarding compliance with C.6.3 (a), an **official measurer**, a race committee or a jury may order a buoyancy test. If the buoyancy is deemed unsatisfactory, the matter shall be referred to the certification **authority** and the **certificate** may be withdrawn until satisfactory remedial measures have been taken.

C.7 HULLS

C.7.1 FITTINGS

- (a) Hatch covers, and drain bungs if fitted, shall be kept in place when sailing.
- (b) Each **hull** shall have at least one inspection hatch. All other fittings are optional.

C.7.2 MODIFICATIONS, MAINTENANCE AND REPAIR.

- (a) Holes not bigger than necessary for the installation fittings and passage of lines may be made in the **hulls**.
- (b) Sealing strips of any suitable material for **centreboard/daggerboard** slots are permitted.
- (c) Routine maintenance such as painting and polishing is permitted without re-measurement and re-**certification**, providing that the intention and the effect is

to polish the **hulls** only.

- (d) The application of vinyl or other film over the **hull** surface is allowed only for the purpose of displaying advertising and graphics. Performance enhancing film, or those with textured or modified surface which would alter or improve the flow around the **hull** are not allowed.

C.8 HULL APPENDAGES

C.8.1 MANDATORY

FITTINGS

- (a) **Rudder** retention devices capable of retaining **rudder** in event of capsize.

C.8.2 LIMITATIONS

- (a) Only two **daggerboards** or **centreboards** and two **rudders** may be used during an event, except when a **hull appendage** has been lost or damaged beyond repair. Such replacement may only be made with the approval of the race committee.
 - (1) The board cases, the **daggerboards** or **centreboards** and the **rudders** shall be positioned in the centre plane of the **hulls**, and the underwater parts of the boards and of the **rudders** shall be symmetrical.
 - (2) The two **rudders** shall be hung on the transoms, one on each transom.

C.9 RIG

C.9.1 FITTINGS

- (a) **Sail** and **mast** adjustment fittings may be fitted.

C.9.2 USE

- (a) When stepped the **mast datum point** shall not be more than 120 mm above the top of the front beam.

C.9.3 LIMITATIONS

- (a) Only one set of **spars** shall be used during an event, except when lost or damaged beyond repair.
- (b) Replacement of damaged **spars** may only be made with the approval of the race committee.

C.9.4 BOOM

- (a) The **boom**, if fitted, may have fittings attached.

C.9.5 BOWSPRIT

- (a) The **bowsprit** shall be fixed in a fore and aft position and shall not be adjustable while sailing
- (b) The **bowsprit** may have fittings attached.
- (c) The **bowsprit** shall have an end cap that is smooth, rounded and blunt.

C.9.6 STANDING RIGGING

- (a) It is NOT permitted to adjust: **mast** rake, tension of **standing rigging**, angle or length of **spreaders** or diamond wire tension.
- (b) The **forestay** shall be attached on the centreline of the **boat**.

(c) **Trapeze** wires may have adjustable height.

C.9.7 RUNNING RIGGING

(a) **Running rigging** shall be led outside the **mast spar**.

(b) With the exception of C.9.7 (a), the way of leading **running rigging** is optional.

C.10 SAILS

C.10.1 LIMITATIONS

(a) The **sail** plan shall consist of one **mainsail**, one jib and one gennaker which shall be carried aboard. **Sails** shall not be replaced during a regatta, except when a **sail** has been lost or damaged beyond repair, then only with permission of the race committee. The *race committee* shall then remove or cross out any **event limitation mark** attached to the replaced **sail**.

(b) **Sails** shall not be altered in any way except as permitted by these **class rules**.

(c) Routine maintenance is permitted without re-measurement and recertification.

(d) **Sails** shall be allocated to **crews** with different weight categories according to C.3.2.

C.10.2 MAINSAIL

(a) IDENTIFICATION

The national letters and sail numbers shall comply with the RRS appendix G.

(b) USE

(1) The **sail** shall be hoisted with a **halyard**. The arrangement shall permit hoisting and lowering of the **sail** whilst afloat.

(2) The **luff** bolt rope shall be in the **spar** groove.

(3) The **mainsail** may be loose footed.

C.10.3 JIB

(a) USE

(1) The **sail** shall be set on the **forestay**.

(2) The **tack point** shall not be fixed below the apex of the bridle wire.

C.10.4 GENNAKER

(a) USE

(1) The **sail** shall be set between the **mast** and the **bowsprit**.

Section D - Hulls

D.1 PARTS

D.1.1 MANDATORY

(a) **Hull** shells

(b) Front beam

(c) Rear beam

(d) Trampoline

D.1.2 OPTIONAL

- (a) Bulkheads
- (b) Sub-decks
- (c) Fittings

D.2 GENERAL

D.2.1 RULES

- (a) The **hull** shall comply with the **rules** in force at the time of initial **certification**.

D.2.2 CERTIFICATION

- (a) Only the controls, measurements and calculations made by an **official measurer** are considered valid.

D.2.3 IDENTIFICATION

- (a) **Hulls** shall have a serial number.
- (b) From 1 November 2009, all new **hulls** shall carry the WS plaques permanently placed on the transoms or on the inside of the **hulls** just below the rear beam.

D.2.4 BUILDERS

- (a) A licence is not required.
- (b) Builders shall supply a builder's declaration, confirming that the **boat** was built to rules in force at the time of manufacture (See Appendix A).

D.3 HULL SHELLS

D.3.1 MATERIALS

- (a) The **hull** shells may be built from epoxy, polyester or vinylester resin, wood, injected plastic, glass fibre, glue, gel coat, paint and/or metal fastenings. A core of PVC or balsa or felt may be used.

D.3.2 CONSTRUCTION

- (a) **Hulls** may be symmetrical or asymmetrical.
- (b) The **hull** shells may be altered locally for fittings and passage of equipment and normal reinforcement.

D.4 BEAMS

D.4.1 MANDATORY

- (a) Front Beam
- (b) Rear beam

D.4.2 CONSTRUCTION

- (a) The beams shall be made of extruded aluminium profiles of constant section.
- (b) The curvature of the beams shall be limited to a maximum of 15 mm.
- (c) The **mast** pivot on the front beam shall be fixed on the centreline of the **boat**.
- (d) The front beam may have a strut and tie of optional material, excluding carbon.
- (e) The rear beam may incorporate a **mainsail** traveller track.

- (f) The front beam may incorporate a jib traveller track and/or a self-tacking system, and **sail** adjustment fittings.
- (g) A local reinforcement is permitted inside the front beam for the **mast** step.
- (h) Local reinforcements are permitted inside the front beam and the rear beam for supporting fixing bolts.
- (i) The **mast** step shall be in a fixed position.
- (j) The beams may accommodate adjustment fittings.
- (k) Any holes for fittings may only be as large as necessary to house the fittings.

D.5 TRAMPOLINE

D.5.1 DEFINITIONS

A Trampoline is an item of equipment with the primary function of carrying the **crew**, which covers the area between the front beam, the rear beam and the **hulls**.

D.5.2 MATERIALS

The type of material used is optional, provided that the body of the sheet of material is capable of being folded flat in any direction without damaging other than by creasing.

D.5.3 CONSTRUCTION

- (a) The Trampoline shall consist of one or more sheets of material.
- (b) Vertical separation of sheets is permitted. The maximum vertical distance between the outer surface of separated sheets shall be 200 mm.
- (c) The Trampoline may partly cover the front beam, the rear beam and/or the **hulls**.
- (d) The following are permitted: stitching, welding, glues, zips, tapes, hook-and-loop fasteners, slides, bolt ropes, storage bags, pouches, holes, fittings and items as prescribed or permitted by other applicable *rules*.

D.6 PLATFORM

D.6.1 CONSTRUCTION

- (a) The **hulls** shall be joined rigidly by a front beam and a rear beam.
- (b) Non-slip surfaces are allowed.

D.6.2 DIMENSIONS

- (a) The maximum **hull length** shall be 5.52 m.
- (b) The maximum **boat beam** shall be 2.60 m.
- (c) The **boat** centre plane is the vertical longitudinal plane of the **boat** that passes through the centre point of the front and rear beams.

D.6.3 FITTINGS

- (a) MANDATORY
 - (1) **Shroud** fittings attachments
 - (2) **Forestay** bridle fittings attachments
 - (3) **Bowsprit** fittings attachments.

- (b) OPTIONAL
 - (1) Fittings for the attachment of the trampoline
 - (2) Fittings for adjustment of **sails** and **rig**
 - (3) Foot loops, toes straps, **trapeze** gear, **crew** restraining line
 - (4) Fittings for **rudders**
 - (5) **Centreboard/daggerboard** retention/placement fittings
 - (6) Inspection hatches.

Section E – Hull Appendages

E.1 PARTS

E.1.1 MANDATORY

- (a) **Rudders**
- (b) Tillers
- (c) Tiller connecting bar
- (d) **Rudder** pins or pintles
- (e) **Rudder** gudgeons.

E.1.2 OPTIONAL

- (a) **Centreboards**
- (b) **Daggerboards**
- (c) Tiller extension.

E.2 GENERAL

E.2.1 RULES

- (a) **Hull appendages** shall comply with the **class rules** in force at the time of **certification**.

E.2.2 MODIFICATIONS, MAINTENANCE AND REPAIR

- (a) **Hull appendages** shall not be altered in any way except as permitted by these **class rules**.
- (b) Routine maintenance such as cleaning and sanding is permitted without remeasurement and **re-certification**.

E.2.3 CERTIFICATION

- (a) An **official measurer** shall **certify hull appendages** and shall number the **certification marks**.

E.2.4 MANUFACTURERS

- (a) Licence is not required to manufacture **hull appendages** (See D.2.4(a)).

E.3 CENTREBOARD/DAGGERBOARD

E.3.1 RULES

- (a) There shall be a maximum of one **centreboard/daggerboard** per **hull**.

E.3.2 MATERIALS

- (a) The **centreboards/daggerboards** may be built from epoxy, polyester or vinylester resin, carbon, wood, glass fibre, foam plastic, glue, gel coat, paint and/or metal fastenings.

E.3.3 CONSTRUCTION

- (a) The **centreboard/daggerboard** shall have no moving parts.
- (b) The cross section of each **centreboard/daggerboard** shall be symmetrical about their centreplane.
- (c) The **centreboard/daggerboards** shall not protrude more than 1400mm from the bottom of the **hull** and shall be fitted so that they cannot protrude below this level.
- (d) Curved **daggerboards** are not allowed. The manufacturing tolerance is 10mm of curvature over the total length of the board.
- (e) The centre of mass of the **daggerboards** shall be above 50% of the length of the board measured from the top of the **daggerboard**. **Ballast** or mass of whatever nature is not permitted.
- (f) **Centreboard/daggerboards** may be angled outwards at the keel from the **boat** centre plane. **Centreboard/daggerboards** shall not be angled inwards at the keel from the **boat** centreplane, except where this is caused by the curvature of the front beam, as per rule D.4.2(b).

E.3.4 WEIGHTS

- (a) The maximum weight of each **centreboard/daggerboard** is 5.5 kg. The weight of each **centreboard/daggerboard** shall be noted on the measurement certificate by the measurer.

E.3.5 FITTINGS

- (a) Pivot bushings, height restraining or adjusting systems may be fitted.

E.4 RUDDER BLADE, RUDDER STOCK AND TILLER

E.4.1 MATERIALS

- (a) The **rudder** blades may be built from epoxy, polyester or vinylester resin, carbon, wood, glass fibre, foam plastic, glue, gel coat, paint and/or metal fastenings.
- (b) Materials for the **rudder** stocks are optional, except carbon.
- (c) Materials for the tiller extension are optional.
- (d) The tiller cross bar shall be made of aluminium profile of constant section.
- (e) The tiller cross bar may have reinforcement in the central fittings.
- (f) The tiller cross bar may have reinforcement to support connection to tiller arms.

E.4.2 CONSTRUCTION

- (a) The centre of mass of the **rudders** shall be above 50% of the length of the **rudder** measured from the top of the **rudder**. **Ballast** or mass use of whatever

nature is not permitted.

- (b) The cross section of each **rudder** blade shall be symmetrical about their centre plane.

E.4.3 FITTINGS

- (a) MANDATORY
 - (1) 2 **rudder** fittings.
- (b) OPTIONAL
 - (1) Pivoting and/or lowering systems.

E.4.4 WEIGHTS

- (a) The minimum weight of each **rudder** assembly comprising blade, stock with fittings and tiller is 3 kg. For **rudders** built before 1 January 1996 **corrector weights** may be added to achieve the minimum weight. The controlled weight shall be noted on the measurement **certificate** by the measurer.

Section F – Rig

F.1 PARTS

F.1.1 MANDATORY

- (a) **Mast**
- (b) **Standing rigging**
- (c) **Running rigging**
- (d) **Bowsprit** including snuffer mouth
- (e) Gennaker snuffer bag

F.1.2 OPTIONAL

- (a) **Boom**

F.2 GENERAL

F.2.1 RULES

- (a) The **spars** and their fittings shall comply with the **class rules** in force at the time of **certification** of the **spar**.
- (b) The **standing** and **running rigging** shall comply with the **class rules**.

F.2.2 MODIFICATIONS, MAINTENANCE AND REPAIR

- (a) **Spars** shall not be altered in any way except as permitted by these **class rules**.
- (b) Routine maintenance such as cleaning and minor repairs is permitted without re-measurement and **re-certification**.

F.2.3 CERTIFICATION

- (a) An **official measurer** shall **certify spars** and shall write the **certificate** number on the **certification mark** of the **mast**.
- (b) **Certification** of **standing** and **running rigging**, **bowsprit** and **boom** is not required.

(c) Each **mast** shall have a **certification mark** on the starboard side.

F.2.4 MANUFACTURER

(a) Licence is not required to manufacture **spars**.

F.3 MAST

F.3.1 DEFINITIONS

(a) MAST DATUM POINT

The **mast datum point** is located at the front edge of the mast **spar**, on the longitudinal axis, on the lower end of the profile. See appendix C.

F.3.2 CONSTRUCTION

- (a) The **mast** extrusion shall be made of aluminium and shall be of constant section throughout its length.
- (b) The **mast** shall have one fixed **sail** groove, which shall be an integral form of the **mast spar** and shall be of the same material.
- (c) The **mast** shall have masthead fittings, which shall include the mainsail sheave and locking device.
- (d) The **mast** shall have a heel fitting attached.
- (e) The **mast** pivot shall be fixed on the centreline of the front beam.
- (f) **Forestay**, diamond wires and shroud tension/rake adjustment devices or fittings are permitted.
- (g) The **mast** shall be measured as part of the **mainsail** area in the measurement process.

F.3.3 DIMENSIONS

- (a) The **mast** shall be watertight from 450 mm above the **mast datum point** upwards.
- (b) The distance between the top of the front beam and the **mast datum point** shall not exceed 120mm.

	Maximum
Mast spar circumference	385 mm
Distance between upper point and front beam	9100 mm
Shroud height	6750 mm
Gennaker hoist height	8150 mm
Top of the front beam to mast datum point	120 mm

F.3.4 FITTINGS

(a) MATERIALS

(1) Carbon fibre is only allowed in cleats, turning blocks and spreaders construction.

(b) MANDATORY

(1) Hounds fittings.

(c) OPTIONAL

(1) Pair of **spreaders** and fittings.

(2) Diamond stay attachment and adjustment fittings

- (3) Gennaker **halyard** guide
- (4) Gennaker **halyard** block and attachments
- (5) Gooseneck fittings
- (6) **Mast** rotation control fittings
- (7) **Mast** may have reinforcement at fittings points
- (8) Cunningham downhaul fittings.

F.4 BOOM

F.4.1 MATERIALS

- (a) The **boom**, if fitted, shall be made of extruded aluminium of constant section.

F.4.2 CONSTRUCTION

- (a) The **boom** shall not be measured as part of the **mainsail** area in the measurement process.

F.4.3 FITTINGS

- (a) Fittings are optional.

F.5 BOWSPRIT

F.5.1 RULES

- (a) The **bowsprit** shall be on the longitudinal centreline of the **boat**.
- (b) The **bowsprit** shall be attached to the front beam.

F.5.2 MATERIALS

- (a) The **bowsprit** shall be made of aluminium of constant section.

F.5.3 CONSTRUCTION

- (a) The **bowsprit** may be fitted with a gennaker retrieval system. This system shall not be of carbon fibre on boats certified after 1 January 2007.

F.5.4 FITTINGS

- (a) MANDATORY
 - (1) Attachment points to **hulls**.
- (b) OPTIONAL
 - (1) Adjustment fittings.
 - (2) Wind indicator(s).

F.5.5 DIMENSIONS

- (a) The length of the **bowsprit** shall not exceed the distance from the centre of the front beam to a vertical line touching the most forward part of the **hull** plus 800 mm, with the **bowsprit** measured when horizontal.

F.6 STANDING RIGGING

F.6.1 MATERIALS

- (a) The **standing rigging** shall be of stranded stainless steel with the exception of **bowsprit** bridles and **trapeze** which may be of rope.

- (b) Fittings, such as cleats, blocks may be made from/or include carbon fibre in their construction.

F.6.2 CONSTRUCTION

(a) MANDATORY

- (1) A **forestay** and **forestay** bridles of 1×19 or 1×7 stranded stainless steel wire of minimum diameter 4 mm.
- (2) **Shrouds** of 1×19 or 1×7 stranded stainless steel wire of minimum diameter 4 mm.
- (3) **Trapeze** wires of stranded stainless steel wire or rope of minimum diameter 2.5 mm.

(b) OPTIONAL

- (1) A pair of diamond wires of 1×19 or 1×7 stranded stainless steel wire of minimum diameter 4 mm.
- (2) The **bowsprit** bridles may be of rope of minimum diameter 2.5 mm.

F.7 RUNNING RIGGING

F.7.1 MATERIALS

- (a) Materials are optional.

F.7.2 CONSTRUCTION

(a) MANDATORY

- (1) **Mainsail halyard**
- (2) **Mainsail sheet**
- (3) **Jib halyard**
- (4) **Jib sheet.**
- (5) **Gennaker halyard**
- (6) **Gennaker sheets**
- (7) **Gennaker retraction lines.**

(b) OPTIONAL

- (1) **Rig** adjustments
- (2) **Sails** adjustments

Section G – Sails

G.1 PARTS

G.1.1 MANDATORY

- (a) **Mainsail**
- (b) **Jib**
- (c) **Gennaker**

G.2 GENERAL

G.2.1 RULES

- (a) **Sails** shall comply with the **rules** in force at the time of **certification**.

G.2.2 CERTIFICATION

- (a) An **official measurer** shall **certify** all **sails**.
- (b) For measurement the battens shall be placed in the **batten pockets** without tension.
- (c) When measuring the bolt rope of the **mainsail** shall be excluded.
- (d) The area and the dimensions of the gennaker (SL1, SL2, SMG, SF) shall be written in an indelible manner near the starboard **tack** by the **official measurer**.

G.2.3 SAILMAKER

- (a) Licence is not required to manufacture **sails**.
- (b) A sailmaker's declaration is required with each **sail** (See Appendix B).
- (c) Each **sail** shall have a plaque or label near the **tack point** that shall be completed by the sailmaker, indelibly marked, with name of manufacturer, materials used, date of manufacture and serial number.

G.3 MAINSAIL

G.3.1 IDENTIFICATION

- (a) The class insignia shall conform with the dimensions and requirements as detailed and be placed in accordance with the diagram contained in Appendix C.

G.3.2 MATERIALS

- (a) The **ply** fibres shall consist only of polyester materials as detailed in the cloth list (Appendix D).
- (b) **Stiffening** shall not incorporate carbon fibre and may consist of:
 - (1) Corner boards
 - (2) Battens.
- (c) **Sail reinforcements**
 - (1) **Primary reinforcement** shall be any woven polyester, or any cloth as detailed in the cloth list
 - (2) **Secondary reinforcement** shall be any cloth as detailed in the cloth list.
- (d) The **window** shall comply with the cloth list.

G.3.3 CONSTRUCTION

- (a) The construction shall be: **soft sail, single-ply sail**.
- (b) The **body of the sail** shall consist of the same woven **ply** or laminated **ply** throughout with the exception of the **window** which may be different.
- (c) The number of **batten pockets** is optional.
- (d) The following are permitted: stitching, glues, tapes, bolt ropes, corner eyes, headboard with fixings, Cunningham eye or pulley, zips, hook-and-loop fasteners, reefing points, battens, **batten pocket patches**, **batten pocket** elastic, **batten pocket** end caps, **mast** and **boom** slides, **leech** line with cleat, tell tales,

sail shape indicator stripes and items as permitted or prescribed by other applicable *rules*.

- (e) From 4 March 2008, a **window** shall be placed in the lower third of the **sail**.

G.3.4 DIMENSIONS

	Minimum	Maximum
Sail area (including the area of the half perimeter of the mast spar)		17.00 m ²
Top width		1000 mm
Upper width at upper leech point 1500 mm from head point (Appendix C)		1290 mm
Angle between the luff and the head (Appendix C)		90°
Window area	0.80 m ²	
Tabling width		115 mm

G.4 JIB

G.4.1 MATERIALS

- (a) The **ply** fibres shall consist only of polyester materials as detailed in the cloth list (Appendix D).
- (b) **Stiffening** shall not incorporate carbon and may consist of:
- (1) Corner boards
 - (2) Battens.
- (c) **Sail reinforcements**
- (1) **Primary reinforcement** shall be any woven polyester, or any cloth as detailed in the cloth list.
 - (2) **Secondary reinforcement** shall be any cloth as detailed in the cloth list.
- (d) The **window** shall comply with the cloth list.

G.4.2 CONSTRUCTION

- (a) The construction shall be: **soft sail, single-ply sail**.
- (b) The **body of the sail** shall consist of the same **woven ply** or **laminated ply** throughout with the exception of the **window** which may be different.
- (c) The jib may have either:
- (1) A maximum of four battens, no external part of which exceeding 250mm from the **leech**,
- OR:
- (2) from 1 March 2007, a maximum of three full length battens, which shall have no moving parts and be made of glass fibre.
- (d) The **leech** shall not be convex.
- (e) The following are permitted: stitching, glues, tapes, corner eyes, headboard with fixings, Cunningham eye or pulley, zips, Velcro and sleeve luffs, battens, **batten pocket patches**, **batten pocket** elastic, **batten pocket** end caps, leech line with cleat, tell tales and items as permitted or prescribed by other applicable *rules*.

(f) From 4 March 2008, a **window** shall be placed in the lower third of the **sail**.

G.4.3 DIMENSIONS

	Minimum	Maximum
Sail area Small Jib		3.60 m ²
Sail area Large Jib		4.30 m ²
Top width		50 mm
Batten width (full length battens)		40 mm
Batten pocket outside width		80 mm
Window area	0.30 m ²	
Tabling width		115 mm

G.5 GENNAKER

G.5.1 MATERIALS

(a) The **ply** fibres shall consist only of nylon or polyester materials as detailed in the cloth list (Appendix D).

(b) **Sail reinforcements**

Primary and **secondary reinforcement** is permitted at the **sail corners** and the recovery points.

(1) **Primary reinforcement** shall be any woven polyester, or any cloth as detailed in the cloth list.

(2) **Secondary reinforcement** shall be any cloth as detailed in the cloth list.

G.5.2 CONSTRUCTION

(a) The construction shall be: **soft sail, single ply sail**.

(b) The **body of the sail** shall consist of the same **woven ply** throughout.

(c) **Laminated ply** of any sort is not allowed anywhere in the gennaker. This includes **leech, luff** and **foot** tapes, corner patches and retrieval points. Reinforcing tapes to secure eyelets or rings are allowed at gennaker corners and retrieval points. Tapes may be polyester or spectra.

(d) The following are permitted: stitching, glues, tapes, corner eyes, recovery line eyes, tell tales, **leech** and **luff** lines and items as permitted or prescribed by other applicable *rules*.

G.5.3 DIMENSIONS

	Minimum	Maximum
Sail area Small Gennaker		19.00 m ²
Sail area Large Gennaker		21.00 m ²
Ratio of half width / foot length	75 %	



International Formula 18 Class Association

Builder’s declaration of rule compliance

In accordance with the International Formula 18 Class Association (IF18CA) Class Rules, I declare that the platform which has been issued the serial number has been constructed in full compliance with the IF18CA Class Rules on the date of

I confirm that compliance with the rules has been established, and technical data sheets on materials shall be made available to IF18CA Chief Measurer at their request.

Builder Declaration	
Full Name:	
Representing:	
Signature:	
Date:	



International Formula 18 Class Association

Sailmaker's declaration of rule compliance

In accordance with the International Formula 18 Class Association (IF18CA) Class Rules, I declare that the following sails have been constructed in full compliance with the IF18CA Class Rules on the date of

Sail	Serial No
Mainsail	
Jib	
Gennaker	

(strike through all that do not apply)

I confirm that compliance with the Class Rules has been established, and technical data sheets on materials shall be made available to the IF18CA Chief Measurer at their request.

Sailmaker Declaration	
Full Name:	
Representing:	
Signature:	
Date:	

APPENDIX C. CLASS DRAWINGS

A.9 INTERNATIONAL CLASS FEE

B.2 CERTIFICATION MARKS

C.6 BOAT

D.4 BEAMS

D.6 ASSEMBLED HULLS

F.3 MAST

F.4 BOOM

F.5 BOWSPRIT

G.3 MAINSAIL

A.9 INTERNATIONAL CLASS FEE
AND ISAF BUILDING PLAQUE

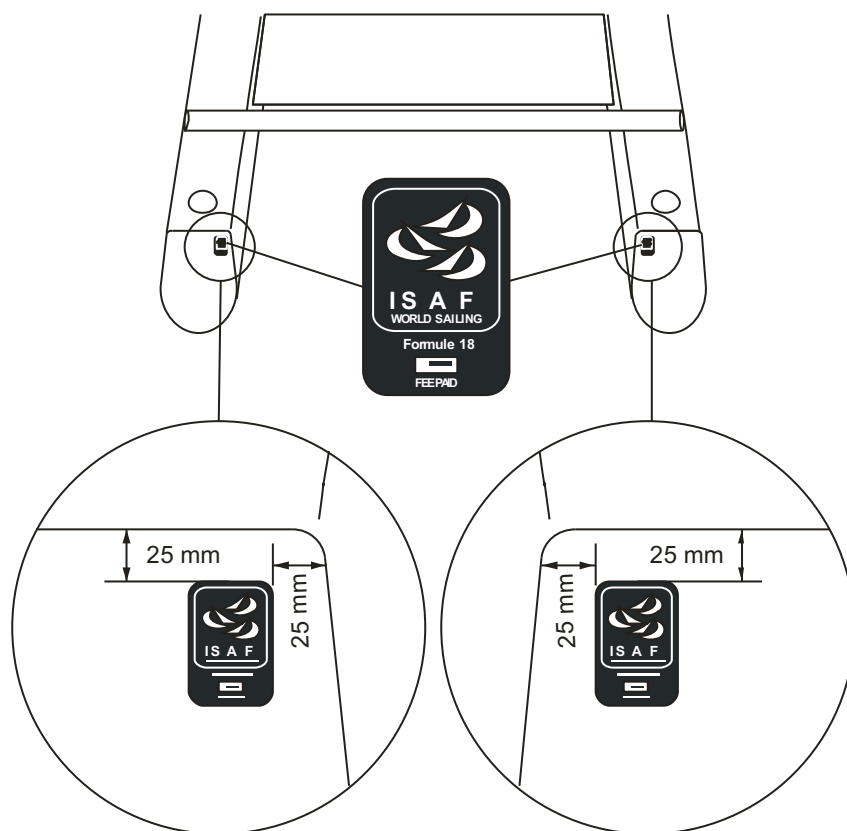

I.F18.A/PCB/10.09

IDENTIFICATION

National Letters

Sail Numbers

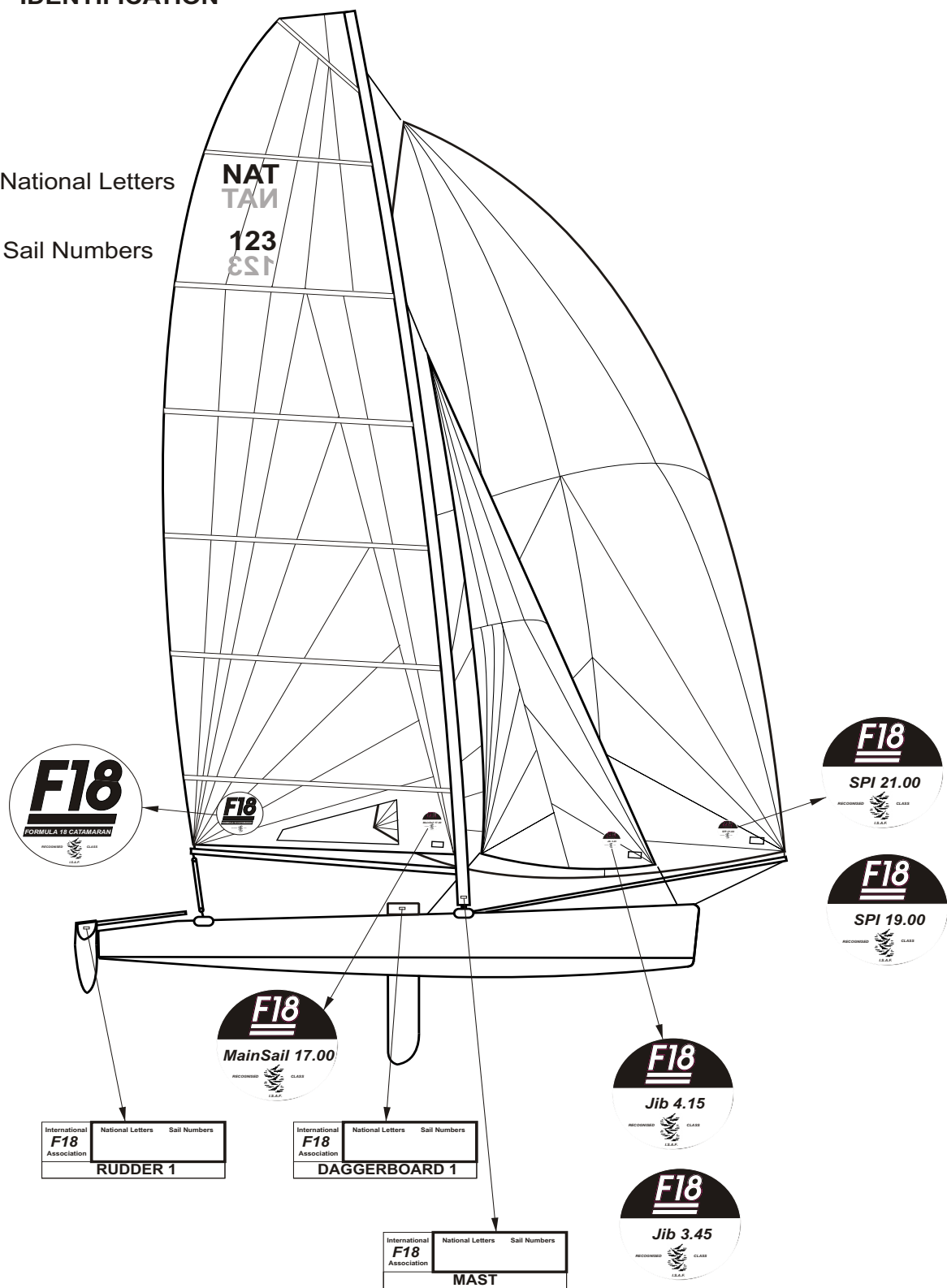

PCB/06/01

C.6 BOAT
C.6.1 WEIGHT
(b) BOAT READY TO SAIL
(3) Identification

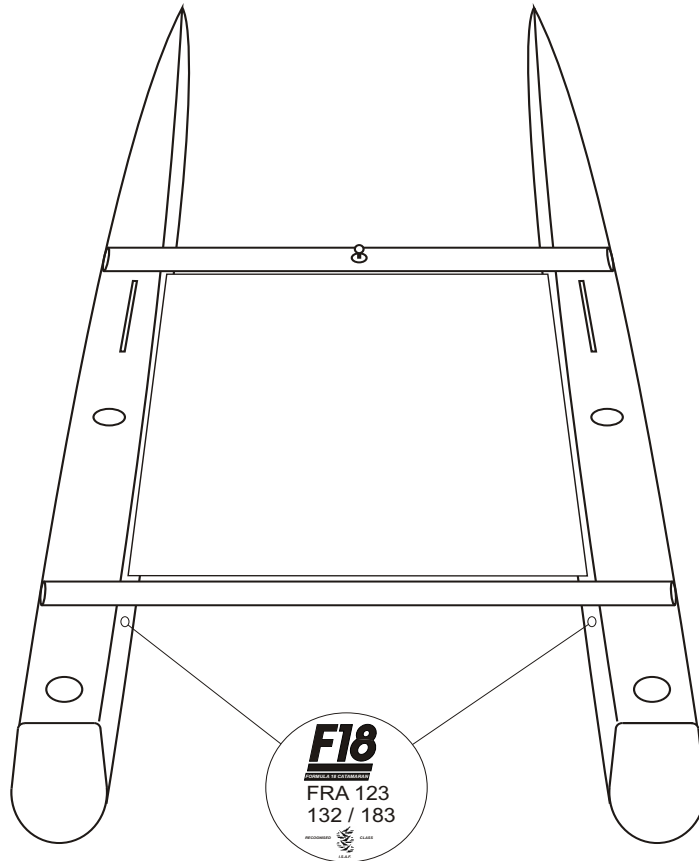

I.F18.A/PCB/06.01

D.4 BEAMS
D.4.2 CONSTRUCTION
D.4.2 (b) The curvature of the beams.

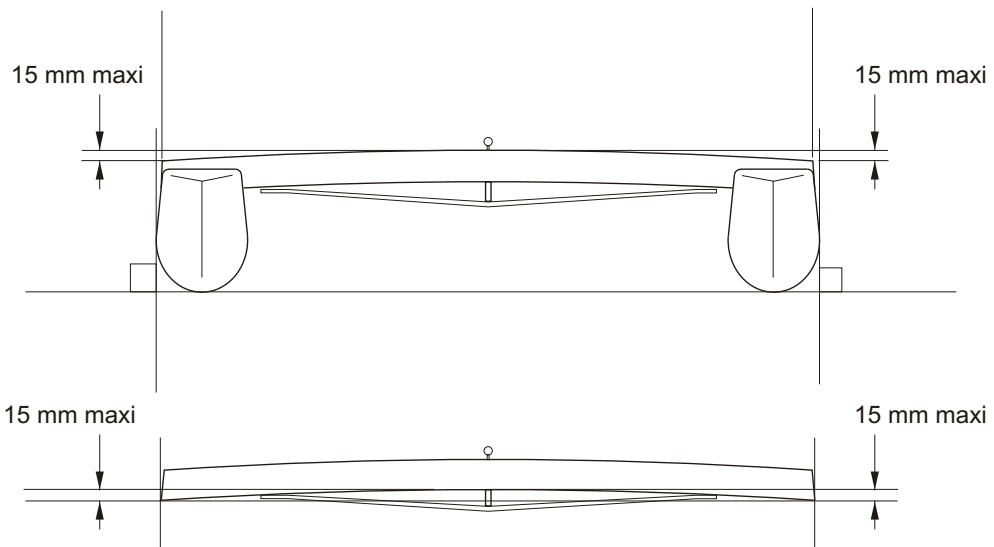

I.F18.A/PCB/10.01

D.4 BEAMS
D.4.2 CONSTRUCTION
D.4.2 (c) The mast pivot on the front beam.

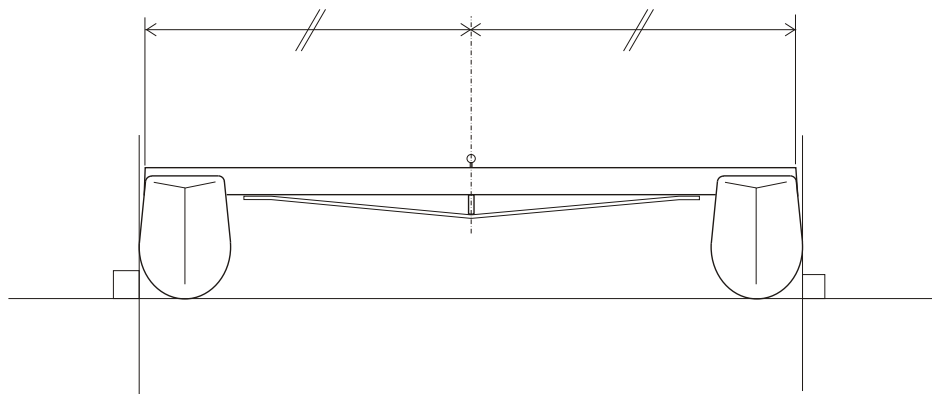

I.F18.A/PCB/10.01

D.6 ASSEMBLED HULLS

D.6.2 DIMENSIONS

D.6.2 (a) maximum hull length.

D.6.2 (b) maximum boat beam.

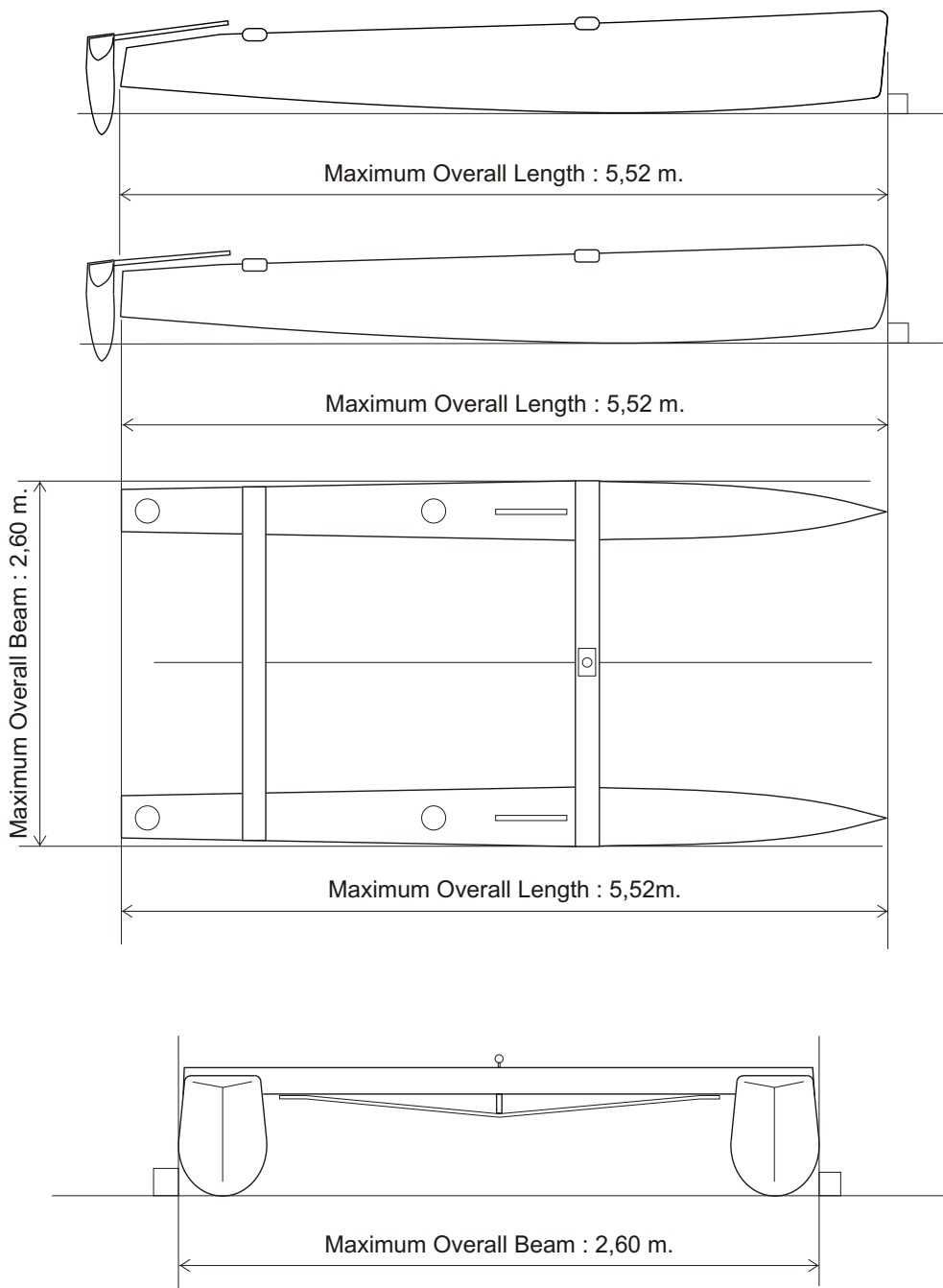

I.F18.A/PCB/06.01

**F.2 GENERAL. F.2.5 (a) Mast Datum Point
F.3 MAST. F.3.2 DIMENSIONS.**

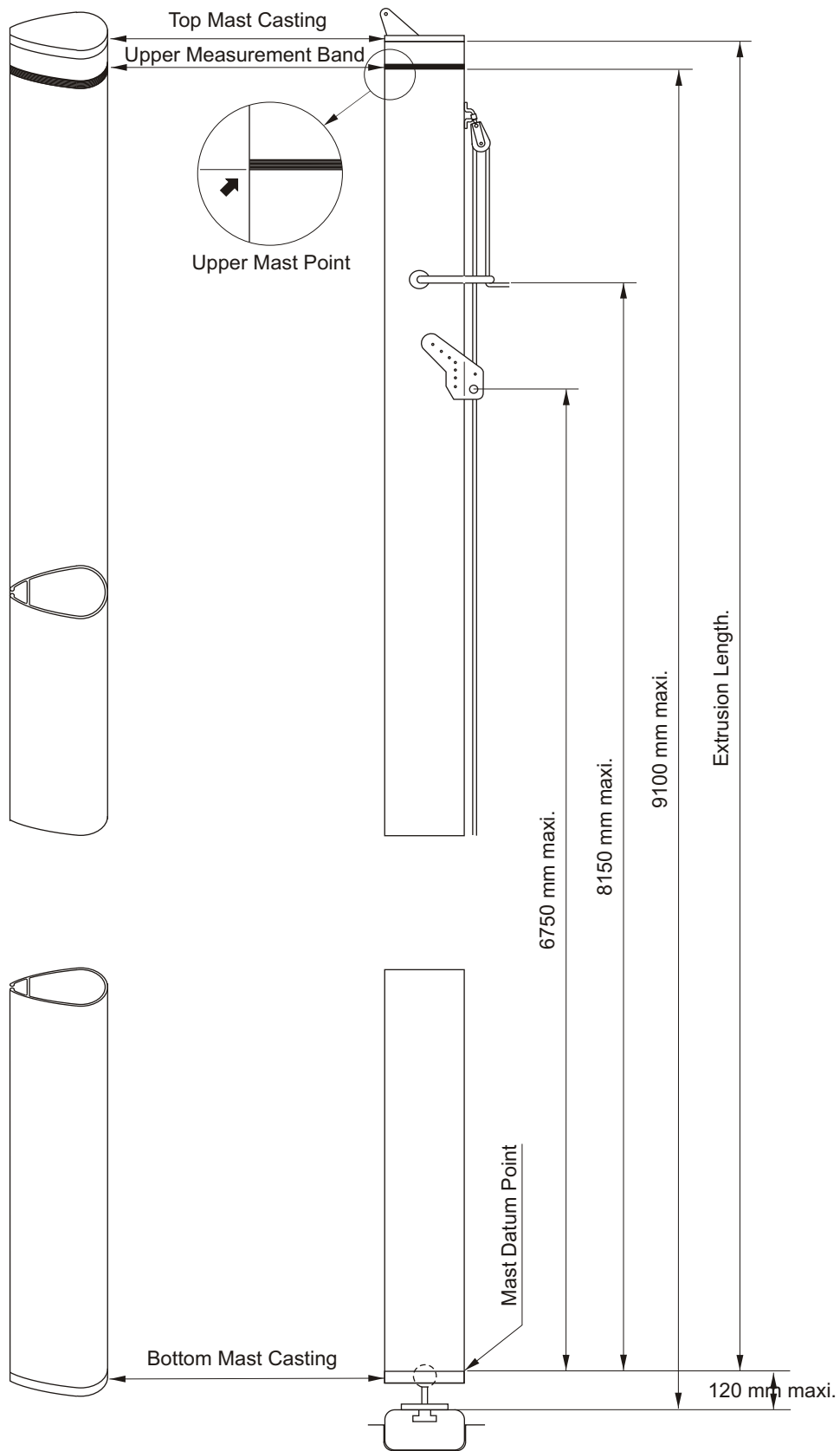

I.F18.A./PCB/10.01

F.3 MAST
F.3.2 DIMENSIONS

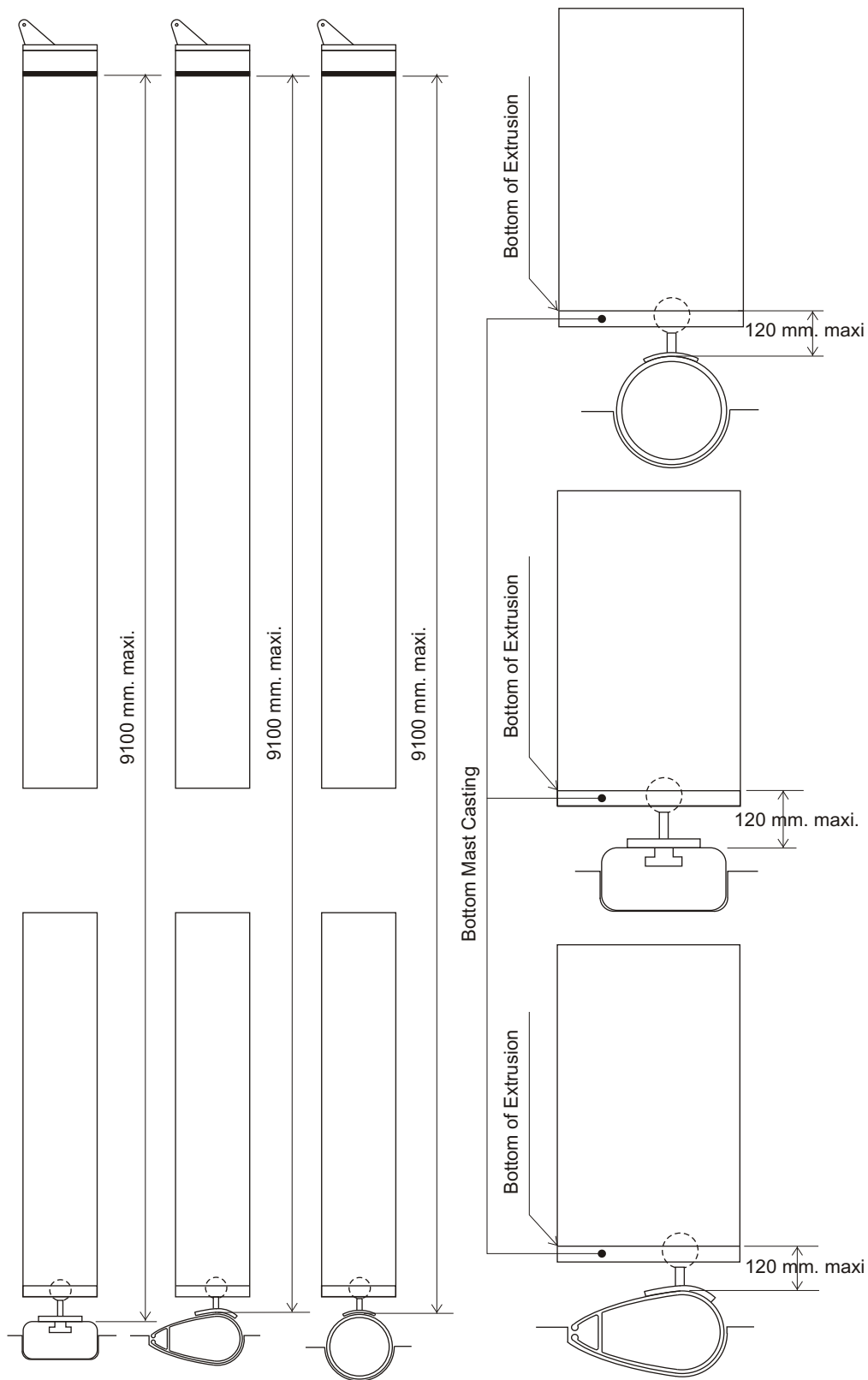

I.F18.A./PCB/05.01

**F.3 MAST
F.3.2 DIMENSIONS
MAST SPAR CIRCUMFERENCE**

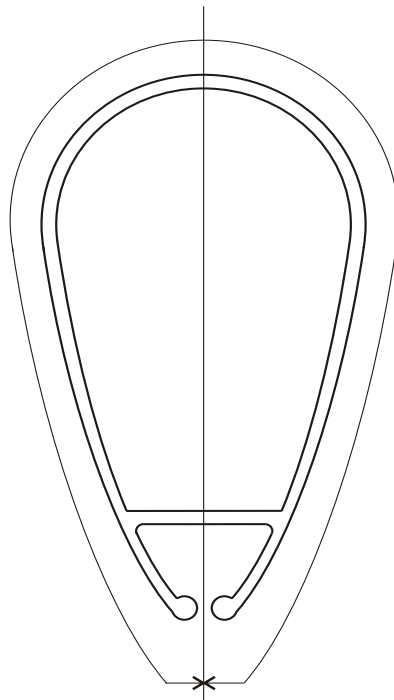

385 mm Maximum

I.F18.A/PCB 01/01

F.3 MAST
F.3.2 DIMENSIONS . SPINNAKER HOIST HEIGHT

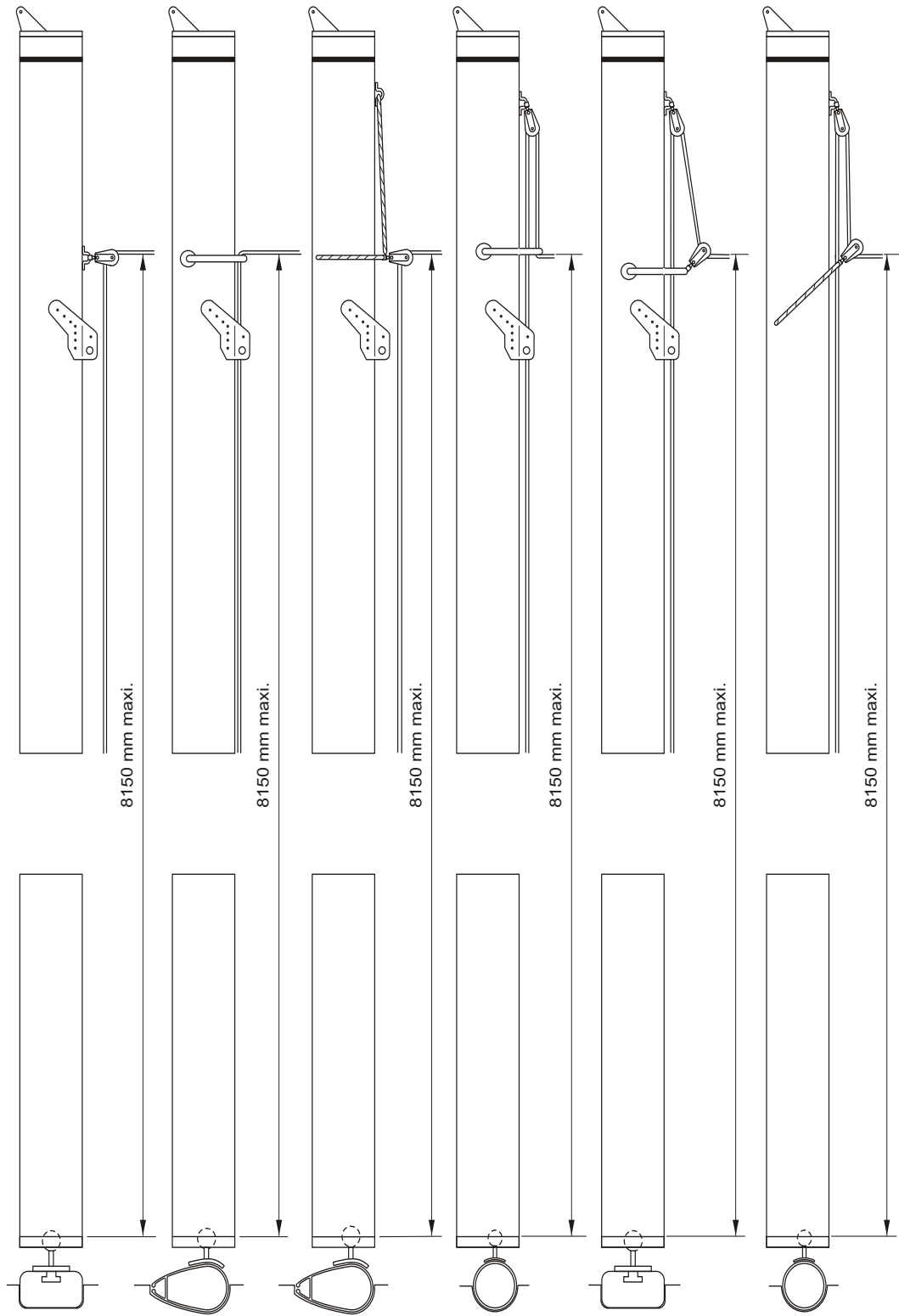

I.F18.A./PCB/05.01

F.4 BOOM
F.4.2 CONSTRUCTION

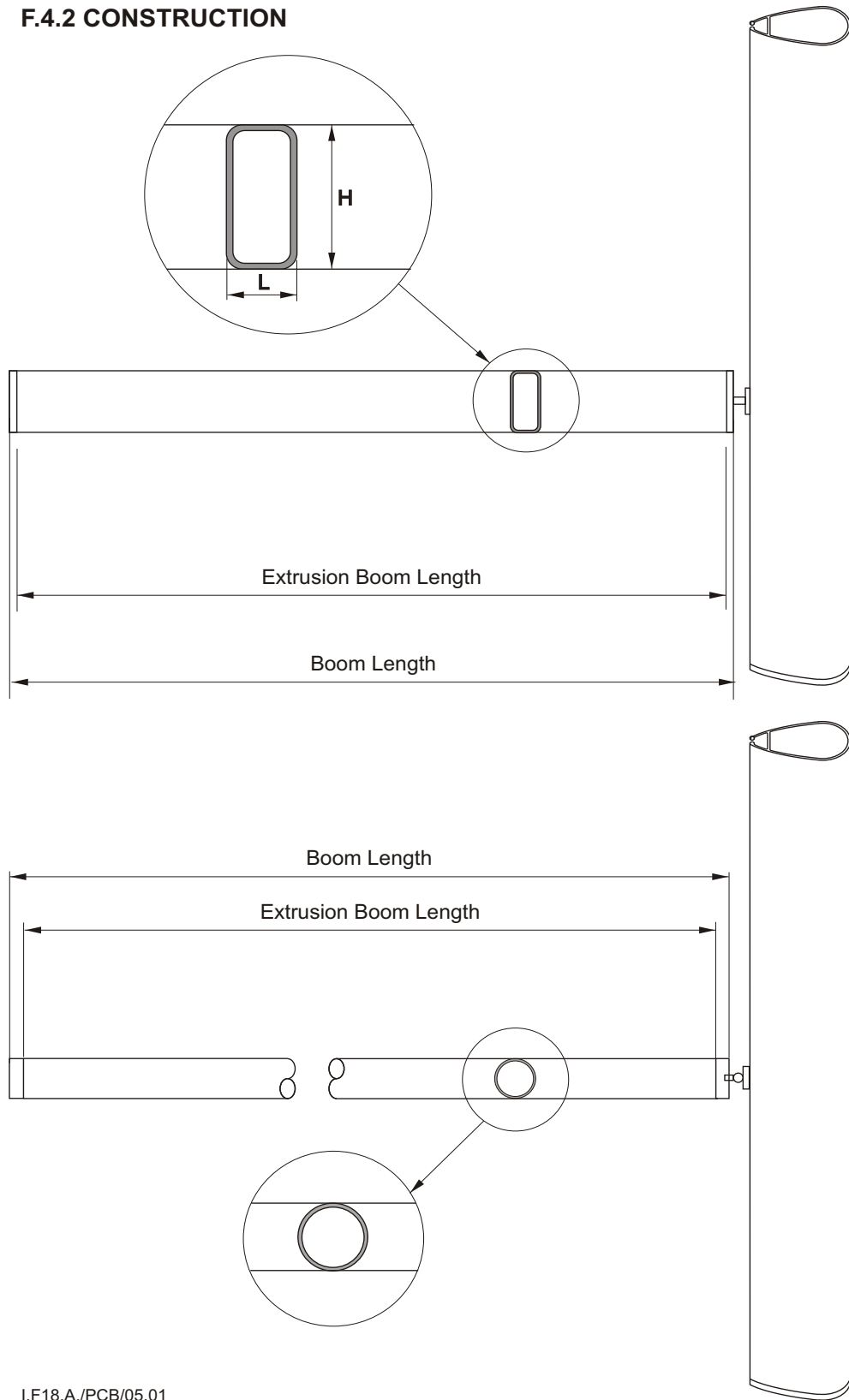

I.F18.A./PCB/05.01

F.5 BOWSPRIT
F.5.5 DIMENSIONS
F.5.5 (a) The maximum length.

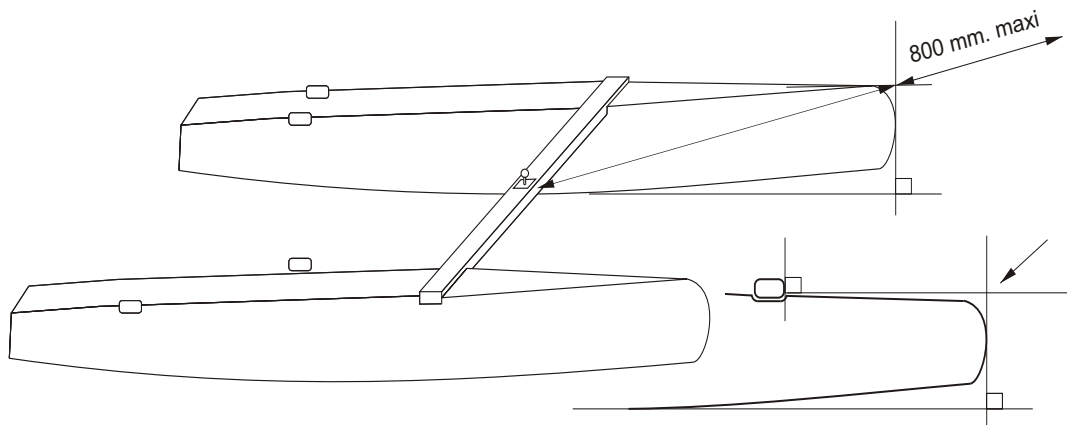
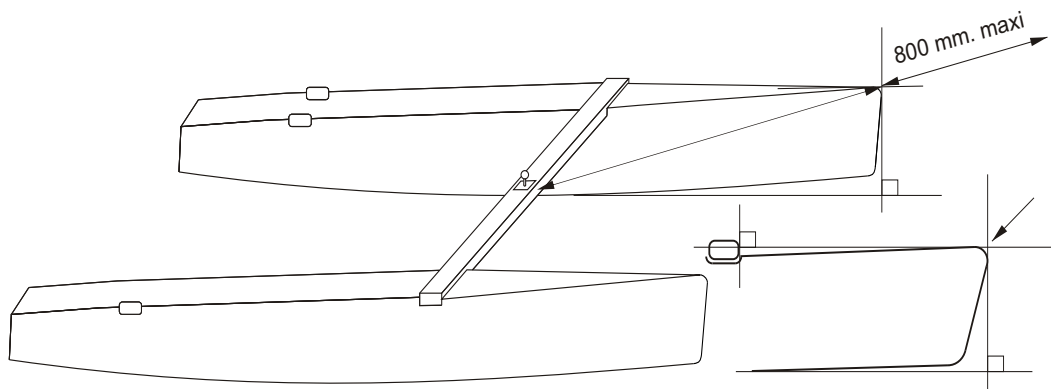
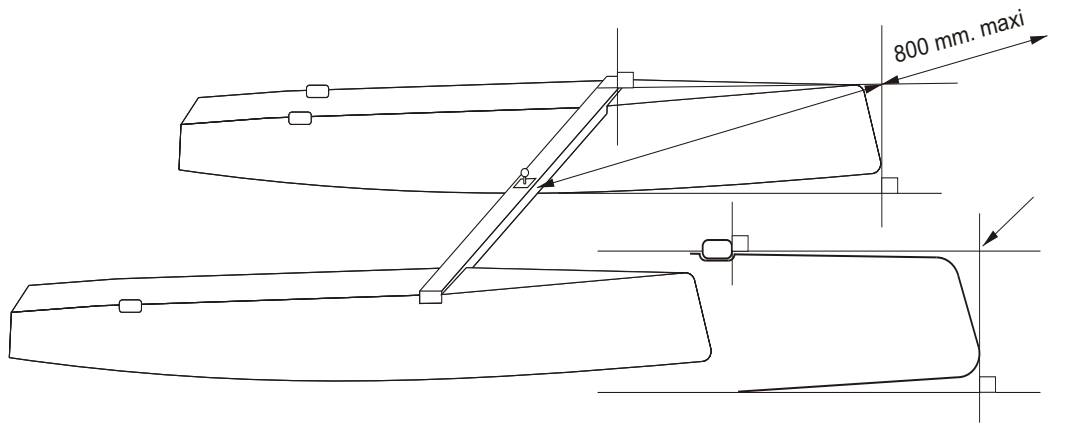

I.F18.A/PCB/11.07

F.5 BOWSPRIT

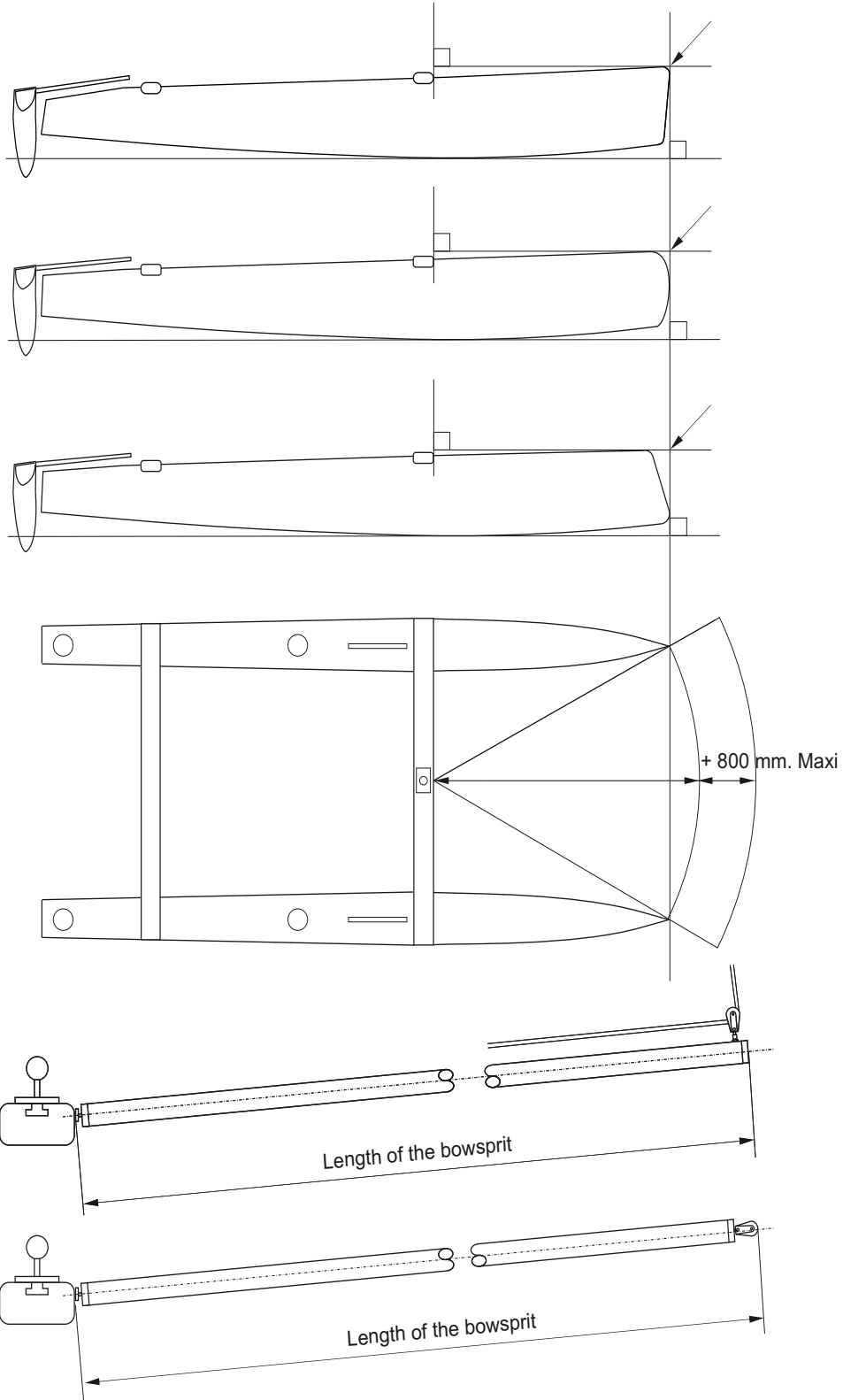

I.F18.A/PCB/11.07

**G.3 MAINSAIL
G.3.5 DIMENSIONS**

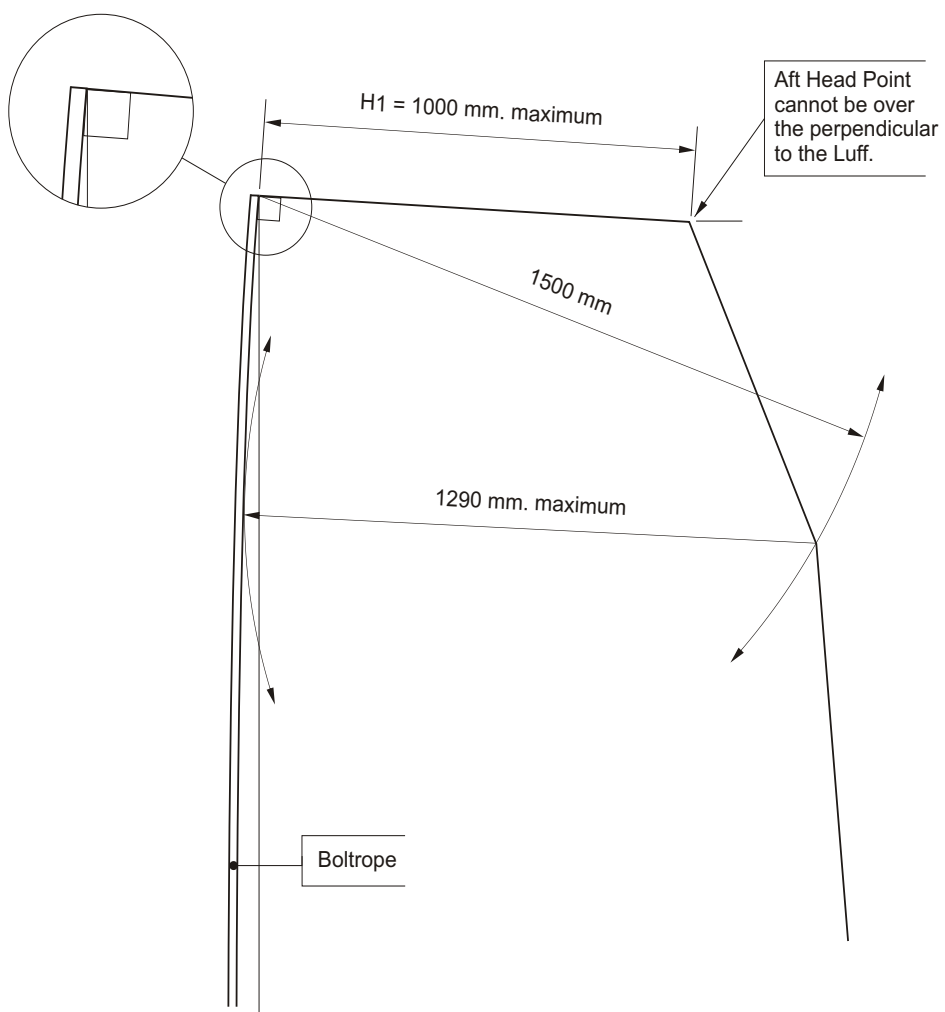

I.F18.A/PCB. Mars 2007

APPENDIX D.

CLOTH LIST

MAINSAIL / JIB

See G.3.2 and G.4.1

Manufacturer	Cloth / Style	Material / Fibre	Thickness (mil)	Status	Weight (g/m ²)
Bainbridge	Diax 120 P	Polyester	1.5	Active	
Bainbridge	Diax 60 P	Polyester	1.5	Active	
Bainbridge	Diax LSP 60	PEN	1.5	Active	
Bainbridge	Diax LSP 90	PEN	1.5	Active	
Challenge	MPTC 3	Polyester	3.0	Active	
Challenge	MPX 06 P	PEN	1.5	Phasing out Dec. 2015	
Challenge	MPX 06 P	Polyester	1.5	Active	
Challenge	MPX 06 P	PEN	2.5	Phasing out Dec. 2015	
Challenge	MPX 06 P	Polyester	2.5	Active	
Challenge	MPX 12 P	PEN	1.5	Phasing out Dec. 2015	
Challenge	MPX 12 P	Polyester	1.5	Active	
Challenge	MW15OB	Polyester	4.0	Active	
Contender	Apen 06	PEN	1.5	Active	
Contender	Apen 06	PEN	2.5	Active	
Contender	Apen 06	PEN	3.0	Active	
Contender	Apen 12	PEN	1.5	Active	
DIMENSION-POLYANT	Flex 08 P	PEN	1.5	Phasing out Dec. 2015	182
DIMENSION-POLYANT	PE 05	PEN	1.5	Active	154
DIMENSION-POLYANT	PE 05	PEN	3.0	Active	206
DIMENSION-POLYANT	PE 10	PEN	1.5	Active	191
DIMENSION-POLYANT	PE 15	PEN	1.5	Active	227
DIMENSION-POLYANT	PX 05	Polyester	1.5	Active	152
DIMENSION-POLYANT	PX 10	Polyester	1.5	Active	193
DIMENSION-POLYANT	PX 15	Polyester	1.5	Active	223
DIMENSION-POLYANT	PXB 10	Polyester	1.5	Active	194
DIMENSION-POLYANT	PXB 15	Polyester	1.5	Active	223
Pryde	F18 X	Polyester	3.0	Active	

WINDOW

Any monofilm/polyester, not containing aramid or carbon fibres and not lighter than 3.0 oz
--

APPENDIX D.

CLOTH LIST

GENNAKER

See G.5.1

Manufacturer	Cloth / Style	Material	Finish	Status	Weight (g/m ²)
Bainbridge	AIRX620NS	Nylon	Silicone	Active	37
Bainbridge	AIRX650	Nylon		Active	40
Bainbridge	AIRX700	Nylon		Active	45
Bainbridge	AIRX720NS	Nylon	Silicone	Phased out	45
Bainbridge	MPEX 70	Nylon		Active	40
Challenge	Elite 40 coated	Nylon		Active	40
Challenge	Elite 45 coated	Nylon		Active	45
Challenge	FibreMax	Nylon		Active	77
Contender	Dynakote 75	Nylon	Silicone	Active	40
Contender	Maxikote 100	Polyester		Active	50
Contender	Maxikote 70	Polyester		Active	38
Contender	Superkote 75	Nylon		Active	40
Contender	Superkote 80	Nylon		Active	42
Contender	Superkote 90	Nylon		Active	46
DIMENSION-POLYANT	6611 UCP Australia	Polyester		Active	34
DIMENSION-POLYANT	7722 UCP	Polyester		Phasing out Dec. 2015	40
DIMENSION-POLYANT	CHS 32	Nylon		Active	44
DIMENSION-POLYANT	CHS 90	Nylon		Phasing out Dec. 2015	96
DIMENSION-POLYANT	Dilon	Nylon		Phasing out Dec. 2019	43
DIMENSION-POLYANT	Formulon 75	Nylon		Phasing out Dec. 2015	39
DIMENSION-POLYANT	RPN 075	Nylon		Active	40
DIMENSION-POLYANT	SCN 32	Nylon	Silicone	Active	46
Mazu Sailcloth	N075C2	Nylon	Silicone	Active	40